

# General technical delivery requirements for steel and iron products

The European Standard EN 10021:1993 has the status of a  
British Standard

UDC 669.14:620.1

## Cooperating organizations

The European Committee for Standardization (CEN), under whose supervision this European Standard was prepared, comprises the national standards organizations of the following countries:

Austria	Oesterreichisches Normungsinstitut
Belgium	Institut belge de normalisation
Denmark	Dansk Standardiseringsraad
Finland	Suomen Standardisoimisliitto, r.y.
France	Association française de normalisation
Germany	Deutsches Institut für Normung e.V.
Greece	Hellenic Organization for Standardization
Iceland	Technological Institute of Iceland
Ireland	National Standards Authority of Ireland
Italy	Ente Nazionale Italiano di Unificazione
Luxembourg	Inspection du Travail et des Mines
Netherlands	Nederlands Normalisatie-instituut
Norway	Norges Standardiseringsforbund
Portugal	Instituto Português da Qualidade
Spain	Asociación Española de Normalización y Certificación
Sweden	Standardiseringskommissionen i Sverige
Switzerland	Association suisse de normalisation
United Kingdom	British Standards Institution

This British Standard, having been prepared under the direction of the Iron and Steel Standards Policy Committee, was published under the authority of the Standards Board and comes into effect on 15 December 1993

© BSI 01-1999

The following BSI references relate to the work on this standard:  
Committee reference ISM/1  
Draft for comment 90/39219 DC

ISBN 0 580 22321 3

### Amendments issued since publication

Amd. No.	Date	Comments

---

# Contents

	Page
Cooperating organizations	Inside front cover
National foreword	ii
<hr/>	
Foreword	2
Text of EN 10021:1993	3
National annex NA (informative) Committees responsible	Inside back cover
National annex NB (informative) Cross-references	Inside back cover
<hr/>	

## National foreword

This British Standard has been prepared under the direction of the Iron and Steel Standards Policy Committee and is the English language version of EN 10021:1993 *General technical delivery requirements for steel and iron products*, published by the European Committee for Standardization (CEN).

A British Standard does not purport to include all the necessary provisions of a contract. Users of British Standards are responsible for their correct application.

**Compliance with a British Standard does not of itself confer immunity from legal obligations.**

### Summary of pages

This document comprises a front cover, an inside front cover, pages i and ii, the EN title page, pages 2 to 14, an inside back cover and a back cover.

This standard has been updated (see copyright date) and may have had amendments incorporated. This will be indicated in the amendment table on the inside front cover.

---

UDC 669.14:620.1

Descriptors: Iron and steel products, steels, delivery, inspection, tests, specifications

English version

## General technical delivery requirements for steel and iron products

Aciers et produits sidérurgiques — Conditions  
générales techniques de livraison

Allgemeine technische Lieferbedingungen für  
Stahl und Stahlerzeugnisse

This European Standard was approved by CEN on 1993-09-24. CEN members are bound to comply with the CEN/CENELEC Internal Regulations which stipulate the conditions for giving this European Standard the status of a national standard without any alteration.

Up-to-date lists and bibliographical references concerning such national standards may be obtained on application to the Central Secretariat or to any CEN member.

This European Standard exists in three official versions (English, French, German). A version in any other language made by translation under the responsibility of a CEN member into its own language and notified to the Central Secretariat has the same status as the official versions.

CEN members are the national standards bodies of Austria, Belgium, Denmark, Finland, France, Germany, Greece, Iceland, Ireland, Italy, Luxembourg, Netherlands, Norway, Portugal, Spain, Sweden, Switzerland and United Kingdom.

**CEN**

European Committee for Standardization  
Comité Européen de Normalisation  
Europäisches Komitee für Normung

**Central Secretariat: rue de Stassart 36, B-1050 Brussels**

## Foreword

This European Standard has been prepared by Technical Committee ECISS/TC 9, Technical delivery conditions and quality control of iron and steel products, the secretariat of which is held by IBN.

With EN 10204, EN 10021 replaces Euronorm 21-1978.

This European Standard shall be given the status of a national standard, either by publication of an identical text or by endorsement, at the latest by March 1994, and conflicting national standards shall be withdrawn at the latest by March 1994.

In accordance with the CEN/CENELEC Internal Regulations, the following countries are bound to implement this European Standard: Austria, Belgium, Denmark, Finland, France, Germany, Greece, Iceland, Ireland, Italy, Luxembourg, Netherlands, Norway, Portugal, Spain, Sweden, Switzerland and United Kingdom.

## Contents

	Page
Foreword	2
1 Scope	3
2 Normative references	3
3 Definitions	3
4 Information to be supplied by the purchaser	4
5 Manufacturing process	5
6 Supply by a processor or an intermediary	5
7 Requirements	5
8 Inspection and testing	6
9 Sorting and reprocessing	8
10 Marking	8
11 Disputes	9
Annex A (informative) Bibliography	13
Annex B (informative) Important standards for testing and analysis of iron and steel	13
Figure 1 — Terms defined in clause 3	9
Figure 2 — Flow chart for tests and retests where the interpretation of results of non-sequential tests is based on individual values only (e.g. for tensile test) for cases where the test unit consists of a single piece	10
Figure 3 — Flow chart for tests and retests where the interpretation of results of non-sequential tests is based on individual values only (e.g. for tensile tests) for cases where the test unit consists of several piece	11
Figure 4 — Flow chart of sequential tests in conjunction with retests	12

## 1 Scope

This European Standard specifies the general technical delivery requirements for all steel products covered by EN 10079 with the exception of steel castings and powder metallurgical products (see annex A).

EN 10 204 describes the inspection documents to be used.

Where the delivery requirements agreed for the order or specified in the appropriate product or material standard differ from the general technical delivery requirements defined in this standard, then it is the requirements agreed for the order or specified in the appropriate product or material standard which shall apply.

## 2 Normative references

This European Standard incorporates by dated or undated reference, provisions from other publications. These normative references are cited at the appropriate places in the text and the publications are listed hereafter. For dated references, subsequent amendments to or revisions of any of these publications apply to this European Standard only when incorporated in it by amendment or revision. For undated references the latest edition of the publication referred to applies.

EN 10020, *Definitions and classification of grades of steel*.

EN 10052, *Vocabulary of heat treatment terms for ferrous products*.

EN 10079, *Definitions of steel products*.

EN 10204, *Metallic products — Types of inspection documents*.

EN 29001, *Quality systems — Model for quality assurance in design/development, production, installation and servicing*.

EN 29002, *Quality systems — Model for quality assurance in production and installation*.

EN 29003, *Quality systems — Model for quality assurance in final inspection and test*.

Euronorm 18<sup>1)</sup>, *Selection and preparation of samples and test pieces for steel and iron and steel products*.

ISO 31-0:1981, *General principles concerning quantities, units and symbols*.

ISO TR 9769, *Steel and iron — Review of available methods of analysis*.

## 3 Definitions

In addition to the definitions in EN 10020, EN 10052 and EN 10079, for the purposes of this standard the following definitions apply.

### 3.1 inspection

activities such as measuring, examining, testing, gauging one or more characteristics of a product or service and comparing these with specified requirements to determine conformity

### 3.2 testing

any operation or action to determine one or more properties or characteristics of a material or product

### 3.3 continuous inspection

regular inspection and testing of the characteristics and/or manufacturing parameters of a product manufactured over a long period normally in large quantities and always to the same specification. The tests and inspection are carried out according to a procedure agreed between the manufacturer and purchaser. This agreement may cover for example specifications on:

- the characteristics or manufacturing parameters to be tested or inspected;
- the condition of the products at the time of testing and inspection;
- the assessment of the test results (frequently statistical assessments);
- the right of the purchaser to verify the proper carrying out of the tests and inspections.

### 3.4 non-specific inspection and testing

inspection and testing carried out by the manufacturer in accordance with his own procedures, to assess whether products made by the same manufacturing process meet the requirements of the order. The products inspected and tested may not necessarily be the products actually supplied

### 3.5 specific inspection and testing

inspection and testing carried out, before delivery, according to the technical requirements of the order, on the products to be supplied or on test units of which the product supplied is part, in order to verify whether these products comply with the requirements of the order

<sup>1)</sup> Until their transformation as European Standards, the indicated EURONORM, or their national corresponding standard, may be used.

### 3.6 inspection representative(s)

one or more individual(s) who is/are either:

- a) the inspector(s) designated in the official regulations;
- b) the manufacturer's authorized representative(s), who is hierarchically independent of the production process, acting on behalf of the purchaser;
- c) the purchaser's authorized representative(s).

### 3.7 test unit

the test unit is the number of pieces or the mass of products to be accepted or rejected together, on the basis of the tests to be carried out on sample products in accordance with the requirements of the product standard or order (see Figure 1)

### 3.8 sample product

item (a sheet, for example) selected from a test unit for the purpose of obtaining test pieces (Figure 1) or for inspection purposes

NOTE In certain cases the sample product may be the sample itself.

### 3.9 sample

a sufficient quantity of material taken from the sample product for the purposes of producing one or more test pieces (see Figure 1)

NOTE In certain cases, the sample may be the sample products itself or the rough specimen.

### 3.10 rough specimen

part of the sample having undergone mechanical treatment, followed by heat treatment where appropriate, for the purposes of producing test pieces (see Figure 1)

### 3.11 test piece

part of the sample, with specified dimensions, machined or unmachined, brought to a required condition for submission to a given test (see Figure 1)

NOTE In certain cases, the test piece may be the sample itself or the rough specimen.

### 3.12 cast (heat) analysis

a chemical analysis representative of the cast (heat) determined by the steelmaker at his discretion in a manner of his choice

### 3.13 product analysis

a chemical analysis carried out on a sample of the product

### 3.14 sequential testing

a group or series of tests from which the average and individual results are used to demonstrate that the requirements of the order and/or product standard have been satisfied

## 4 Information to be supplied by the purchaser

4.1 The purchaser shall select the steel type, the shape of the product and the dimensions, taking the intended processing and use into account. He may take the manufacturer's advice in making his choice.

The order shall provide all the information necessary for describing the product required and its characteristics and details concerning delivery such as:

- a) mass, length, area, number of pieces to be delivered;
- b) the product form (it may be a drawing number for example);
- c) the nominal dimensions;
- d) the tolerances on the characteristics in a), b) and c);
- e) the designation of the steel;
- f) delivery condition (type of heat treatment, surface treatment etc);
- g) specific requirements for surface and/or internal quality (see 7.4);
- h) the type of inspection document required and, where not specified in the product standard, the inspection and testing requirements (see clause 8);
- i) where applicable, the application of one of the quality assurance systems given in EN 29001, 29002 or 29003;
- j) requirements for marking, packing and loading;
- k) any optional (supplementary) requirements provided for by the product standard to apply;
- l) the applicable European Directives, if any.

4.2 The information in 4.1 shall be specified either:

- a) by reference to one or more standards or;
- b) in the absence of a standard, by stipulation of the characteristics and conditions required.



If, in an order, reference is made to a given standard without specifying its edition date, this reference shall be interpreted as being the edition current at the date of placing the order.

**NOTE** If there is any doubt concerning the current edition of the standard, the edition of the standard to be used shall be agreed between the supplier and the purchaser.

## 5 Manufacturing process

The manufacturing process shall be left to the discretion of the manufacturer unless otherwise agreed at the time of order or otherwise specified in the product standard.

**NOTE** The manufacturing process covers all operations up to the delivery of the product.

## 6 Supply by a processor or an intermediary (also specified in EN 10204, clause 4)

When a product is supplied by a processor or an intermediary, they shall submit to the purchaser, without any changes to it, the manufacturer's documentation, as described in EN 10204.

This documentation from the manufacturer shall be accompanied by suitable means of identification of the product, in order to ensure the traceability between the product and the documentation (see clause 10).

If the processor or intermediary has changed the state or dimensions of the product in any way whatever, he shall supply an additional document of compliance for these particular new conditions.

This also applies to all special requirements given in the order and not defined in the manufacturer's documentation.

## 7 Requirements

### 7.1 General

The products shall comply with the requirements of the order. In consequence the manufacturer shall carry out appropriate process control, inspection and testing to satisfy himself that the delivery complies with the quality and dimensional requirements of the order, irrespective of the type of inspection document required. (See clause 8).

### 7.2 Chemical composition

Requirements concerning the chemical composition shall be considered to refer to the cast analysis unless they refer expressly to the product analysis.

### 7.3 Mechanical properties

**7.3.1** Where, in the product standard, the mechanical properties are specified by dimensional categories such as thickness, diameter etc, the dimension to be considered is the nominal dimension of the product at the prescribed location for taking samples for mechanical tests.

**7.3.2** In the absence of any specification in the order or the product standard, the mechanical properties relate to the as-delivered condition of the products.

**7.3.3** Where an impact-energy value is specified, without any further information, it shall be taken to represent the average value of those individual tests which shall be assessed as described in 8.3.4.2.

### 7.4 Surface and internal quality

#### 7.4.1 General

All products shall have a workmanlike finish. Minor surface and internal imperfections, which may occur under normal manufacturing conditions shall not be grounds for rejection.

Detailed requirements referring to the surface and internal quality shall, where appropriate, be agreed at the time of enquiry and order, by reference to the appropriate European Standard or other relevant standard if no European Standard exists (see annex A).

#### 7.4.2 Detection of discontinuities

The use of special techniques (radiography, ultrasonics, magnetic detection etc.) to detect discontinuities as well as the number of products to be tested per test unit and the procedures for interpreting the results, when required, shall be as specified in the product standard or as agreed at the time of ordering.

#### 7.4.3 Removal of discontinuities

Surface discontinuities may be removed by mechanical or thermal means (for example by flaming) provided that the dimensions and properties of the product remain within the limits specified in either the order, product standard, dimensional standard or surface quality standard.

#### 7.4.4 Repairs by welding

Where there is no provision in the product standard or order the purchaser or the inspector may permit local repairs by welding. This agreement may apply either to the whole or only to a part of the consignment and may include agreements on the welding procedure.

## 8 Inspection and testing

### 8.1 Type of inspection documents and type of inspection and testing

**8.1.1** When ordering, the purchaser shall state which type of document [see 4.1 h)], if any, is required (see EN 10204), thereby indicating the required type of inspection and testing: non-specific or specific. If non-specific inspection and testing is required see 8.2. If specific inspection and testing is required see 8.3.

**8.1.2** In special cases specific inspection and testing may be replaced by continuous inspection (see 3.3) carried out by the manufacturer.

### 8.2 Non-specific inspection and testing

The purchaser may require, that on the basis of non-specific inspection and testing a certificate of compliance with the order (clause 2.1 EN 10204) or a test report, (clause 2.2 EN 10204) is to be furnished by the manufacturer. When the purchaser requires a test report he shall, if the product standard does not cover such detail, indicate for which product characteristics test results shall be given in this document.

### 8.3 Specific inspection and testing

#### 8.3.1 General

##### 8.3.1.1 Information to be supplied

Where the purchaser specifies that compliance with the requirements of the order is to be verified by specific inspection and testing, the enquiry and order shall cover:

- the type of document required: an inspection certificate type 3.1A or 3.1B or 3.1C or an inspection report type 3.2 (see EN 10204), and, if not specified in the product standard,
- the testing frequency (see 8.3.2);
- the requirements for sampling and for the preparation of the samples and test pieces (see 8.3.3);
- the test methods (see 8.3.4);
- the identification of test units if any;

and, in the case of inspection certificates and inspection reports to be signed by external inspectors, the address of the inspection body.

#### 8.3.1.2 Place of specific inspection and testing

The inspection and testing is normally carried out at the manufacturer's works. If the necessary facilities are not available at the manufacturer's works, the inspection and testing shall be carried out at another place agreed between the two parties or at an establishment accredited by a recognized organization, preferably in the country of manufacture. In this latter case, the products shall not be delivered before receipt of the test results by the manufacturer.

#### 8.3.1.3 Submission for specific inspection and testing

The inspection representative shall be informed, by the manufacturer or his authorized representative, of the date of availability of part or all of the consignment for specific inspection and testing. Reference shall be made to the order.

The manufacturer and the inspection representative shall agree the time and date of the inspection and testing in order to avoid interference with the normal operation of the works. If the external inspection representative does not attend on the agreed date, and, in order not to disturb the manufacturing process the inspection representative authorized by the manufacturer may carry out the acceptance operations himself and provide the purchaser, or his representative, with the inspection document, unless this was expressly forbidden.

A submission note referring to the order, or to the available parts of the order, shall be delivered to the inspection representative not later than the beginning of the inspection/testing procedure.

#### 8.3.1.4 Rights and duties of the inspection representative

In order to carry out the agreed inspection and testing, the inspection representative shall have free access, at the agreed time, to the places, where the products to be tested/inspected are manufactured and stored. He may select the sample products from the test unit from which the samples are to be taken in conformity with the specifications. He shall have the right to be present during the selection of samples, preparation (machining and treatment) of test pieces and of witnessing the tests. He shall observe all the relevant instructions in force in the manufacturer's works and particularly the safety rules. The works shall have the right to have him accompanied by a representative of the works.

The testing/inspection procedures shall be carried out so that disturbance of the normal run of production is minimized.

**8.3.1.5 Traceability during testing**

During the test operations, the manufacturer shall be able to provide traceability between the sample products, samples and test pieces to the test units, to which they belong.

**8.3.2 Testing frequency****8.3.2.1 Formation of test units**

For each type of test the test unit shall be specified in the product standard or the order. Such specifications are normally based on the indication of whether the test unit shall be composed only of products of either one of the following:

- the same cast (heat);
- the same casting sequence;
- the same rolling unit;
- the same heat treatment condition or heat treatment batch;
- the same product form;
- the same thickness range;

or any combination of those and whether the maximum size of the test unit is restricted by weight or number of pieces.

In certain cases the test unit may consist of an individual product.

**8.3.2.2 Number of sample products, samples and preparation test pieces.** For each type of test, the number of sample products to be taken for each test unit, the number of samples to be taken for each sample product and the number of test pieces to be taken per sample shall be as specified in the product standard or order.

**8.3.3 Sampling conditions and test pieces.** The general conditions of EURONORM 18 and the specifications of the product standard or order for the location, direction and preparation of samples and test pieces shall apply.

**8.3.4 Test procedures**

**8.3.4.1 Test method and equipment.** Tests shall be carried out, and the results presented, in accordance with the corresponding European Standard; where no such European Standard exists other test methods shall be used which shall be agreed at the time of order [see 4.1 h)].

All inspection measuring and test equipment used by the supplier to verify characteristics for which specific requirements are included in the order or product standard shall be calibrated and adjusted against certified equipment having a known valid relationship to nationally recognized standards, where such standards exist, and be so maintained. Where such standards do not exist the basis for calibration shall be documented. The supplier or his authorized representative shall maintain calibration records for inspection, measuring and test equipment. The accuracy of the measuring or testing equipment shall be sufficient in relation to the specified values and tolerances.

The chemical composition may be determined by chemical, physical or spectrochemical methods of analysis (see ISO TR 9769). In cases of arbitration, the method to be used shall be agreed.

Annex B contains a list of some of the major European Standards for testing and analysis.

**8.3.4.2 Assessment of results of sequential tests.**

The assessment of some results is carried out in a sequential manner (see 3.14 and 8.3.4.3.3). The following example refers to impact tests.

- a) The averaged value of a set of three test pieces shall meet the specified requirement. One individual value may be below the specified value, provided that it is not less than 70 % of that value.
- b) If the conditions under a) are not satisfied then an additional set of three test pieces may be taken at the discretion of the manufacturer from the same sample and tested. To consider the test unit as conforming, after testing the second set, the following conditions shall be satisfied simultaneously:
  - i) the average value of six tests shall be equal to or greater than the specified minimum value;
  - ii) not more than two of six individual values may be lower than the specified minimum value;
  - iii) not more than one of the six individual values may be lower than 70 % of the specified value.

c) If these conditions are not satisfied the sample product is rejected and retests are carried out on the remainder of the test unit (see 8.3.4.3.3).

The assessment of some other tests e.g. tensile testing in the thickness direction, is carried out in a similar manner.

### 8.3.4.3 Retests

#### 8.3.4.3.1 General

Where one or more tests given unsatisfactory results; subject to the following exception, the manufacturer may either withdraw the test unit concerned or require re-tests in accordance with the procedures described in 8.3.4.3.2 and 8.3.4.3.3.

If the result of a test should deviate significantly from the specified requirements for the steel type to be supplied, so that there is a suspicion that products have become mixed, then the procedure described in clause 9 shall be used.

#### 8.3.4.3.2 Non-sequential tests

Where the unsatisfactory result comes from tests for which no average, but only individual values are specified (e.g. tensile test or end quench hardenability), the following shall be carried out.

a) The test unit is a single piece (see Figure 2).

Two new tests of the same type as the one giving an unsatisfactory result shall be carried out.

Both new tests shall give satisfactory results. If not, the product shall be rejected.

b) The test unit is more than one piece (e.g. by case or heat treatment condition) (see Figure 3).

The manufacturer may, at his discretion, retain in the test unit the sample product from which the unsatisfactory test results has been obtained.

i) If the sample product is withdrawn from the test unit, the inspection representative shall designate, within the same test unit two other products of his choice. One more test of the same type shall then be carried out on test pieces from each of these sample products, under the same conditions as for the first tests; both new tests shall give satisfactory results.

ii) If the sample product is retained in the test unit, the procedure is as indicated in i) but one of the new test pieces shall be taken from the sample product retained in the test unit; both new tests shall give satisfactory results.

#### 8.3.4.3.3 Sequential tests

Where the unsatisfactory result arises from the sequential method as defined in 8.3.4.2 (see Figure 4), the following shall be carried out.

As stated in 8.3.4.2 the sample product which has not given satisfactory results shall be rejected. The procedure shall be as indicated in 8.3.4.2 b) i), instead of one new test carrying out one new set of three tests on each of two different products from the remainder of the test unit, both of which shall give satisfactory results. In this case, 8.3.4.2 b) no longer applies.

### 8.4 Invalidation of test results

Test results which are due to improper sampling and/or preparation of test pieces and/or to tests carried out improperly shall be considered invalid.

### 8.5 Rounding of results of mechanical and chemical tests

Unless otherwise specified in the order or product specification; for the purpose of deciding whether a test result meets a specified value, results of mechanical and chemical tests shall be expressed by or, if needed, be rounded to the same number of significant figures as in the specified value, using either the rules specified in the testing standards or the rules according to ISO 31-0 Annex B, rule A.

NOTE When using digital display measuring devices, the number of digits shown may be in excess of the precision of the testing device and/or the test method.

## 9 Sorting and reprocessing

The manufacturer has the right to carry out sorting or re-processing (e.g. heat treatment, machining, rolling, drawing etc.) of non-conforming products, either before or after the re-tests, and to submit these products as a new test unit in accordance with 8.3.2.

Where no reprocessing, only sorting, has been applied the new inspection procedure shall only apply to the requirements which were not complied with at first inspection and testing. The manufacturer shall state to the inspection representative the method of sorting used or the re-processing.

## 10 Marking

The manufacturer shall identify the delivery either by marking the product or the consignment in accordance with the product standard or the agreement at the time of order. In the absence of such requirements the manufacturer shall use the type of identification of his choice taking into account the following.

a) When a specific inspection was ordered (that means when an inspection document 2.3, 3.1A, 3.1B, 3.1C or 3.2 is to be provided) the delivery units or products shall be marked so that traceability between these and the document is possible.

b) In all other cases the delivery or products shall be marked so that at least

- the manufacturer;
  - the steel type; and, where necessary
  - the treatment condition;
- are traceable.

## 11 Disputes

In case of dispute the sampling conditions and the test methods used to evaluate the disputed characteristics shall be in accordance with the requirements of 8.3.3 and 8.3.4 of this European Standard.

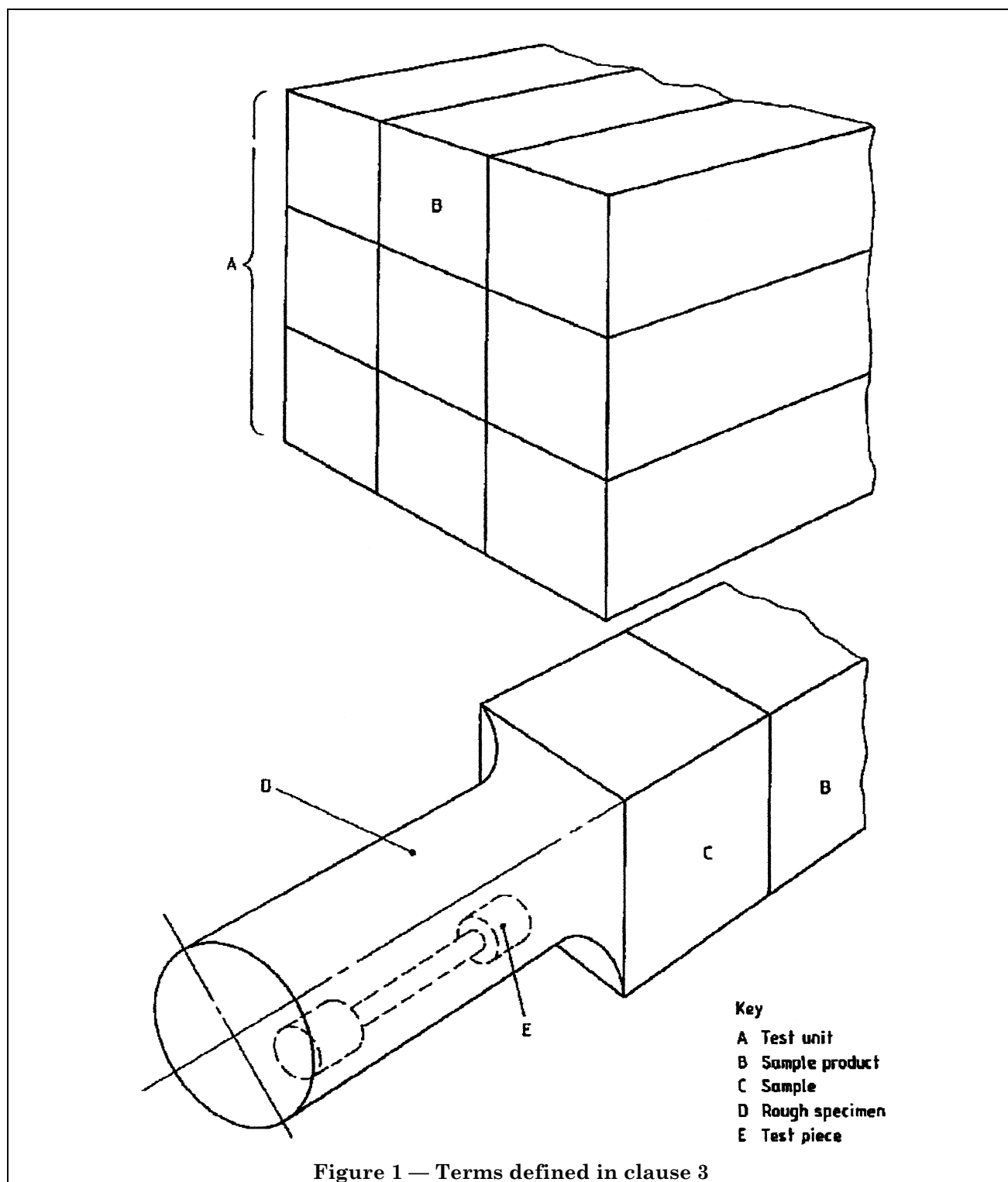

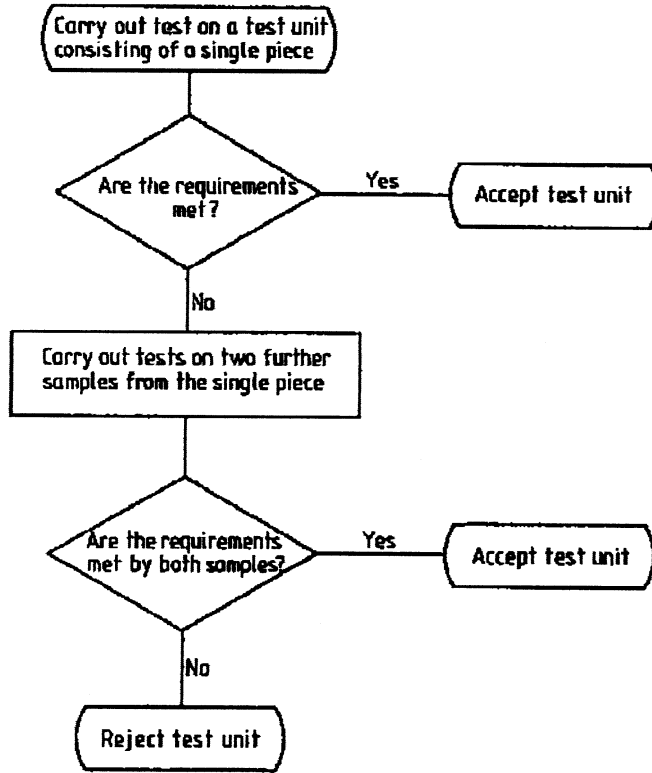

Figure 2 — Flow chart for tests and retests where the interpretation of results of non-sequential tests is based on individual values only (e.g. for tensile test) for cases where the test unit consists of a single piece

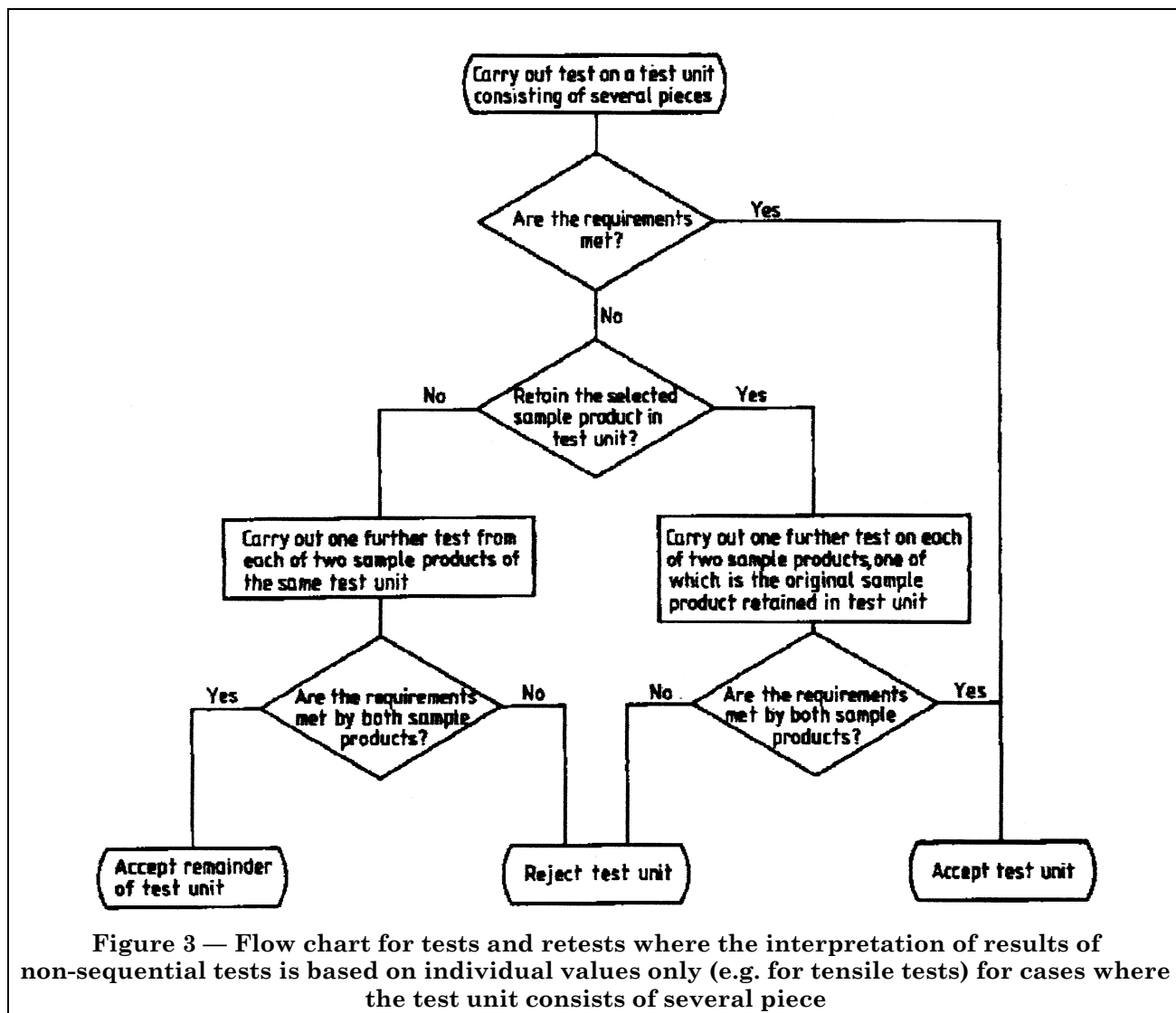
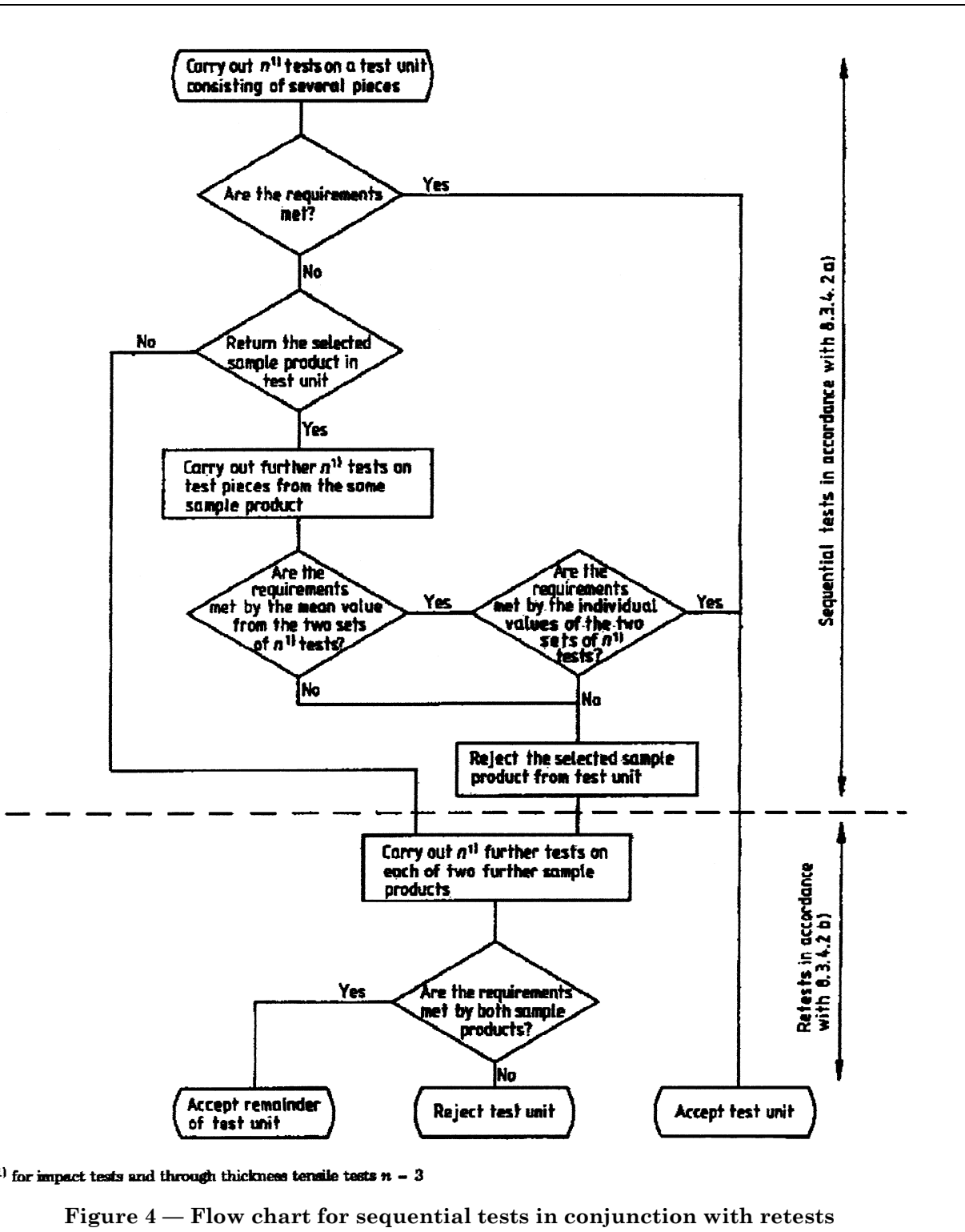

Figure 3 — Flow chart for tests and retests where the interpretation of results of non-sequential tests is based on individual values only (e.g. for tensile tests) for cases where the test unit consists of several piece





**Annex A (informative annex)****Bibliography**

EN 10163, *Delivery requirements for surface conditions of hot rolled steel plates, sheets, wide flats and sections.*

ISO 3954, *Powders for powder metallurgical purposes — Sampling.*

ISO 4489, *Sintered hardmetals — Sampling and testing.*

ISO 4990, *Steel castings — General technical delivery requirements.*

EN 10164, *Steel flat products with specified through thickness properties — Technical conditions of delivery<sup>2)</sup>.*

prEN 10221, *Surface quality classes for hot rolled bar and rod; technical delivery conditions<sup>2)</sup>.*

**Annex B (informative)****Important standards for testing and analysis of iron and steel**

Euronorm 12, *Bend test on steel sheet and strip under 3 mm thick.*

Euronorm 103, *Determination of the ferritic or austenitic grain size of steels.*

Euronorm 121, *Determination of resistance to intergranular corrosion of austenitic stainless steels. Corrosion test in a nitric medium by measurement of loss in mass (Huey test).*

Euronorm 114, *Determination of the resistance to intergranular corrosion of austenitic stainless steels. Corrosion test in a sulphuric acid — Copper sulphate medium. (Monypenny-Strauss test).*

Euronorm 23, *End quench hardenability test for steel (Jominy test).*

EN 10003, *Part 1: Metallic materials — Brinell hardness test — Method of test.*

EN 10 045/1, *Metallic materials — Charpy impact test — Part 1: Method of test.*

prEN 10 109, *Part 1: Metallic materials — Hardness testing — Rockwell test (scales A-B-C-D-E-F-G and H) and superficial Rockwell test (scales 15 N — 30 N — 45 N, 15 T, 30 T and 45 T)<sup>2)</sup>.*

EN 10 002-1, *Metallic materials — Tensile tests — Part 1: Method of test.*

Euronorm 13, *Reverse bend test on steel sheet and strip under 3 mm thick.*

ISO/TR 9769, *Steel and iron — Review of available methods of analysis.*

Euronorm 5, *Vickers hardness test for steel.*

<sup>2)</sup> In preparation.



## National annex NA (informative)

### Committees responsible

The United Kingdom participation in the preparation of this European Standard was entrusted by the Iron and Steel Standards Policy Committee (ISM/-) to Technical Committee ISM/1 upon which the following bodies were represented:

British Constructional Steelwork Association Ltd.  
 British Forging Industry Association  
 British Railways Board  
 British Steel Industry  
 British Welded Steel Tube Association  
 Department of Trade and Industry (Minerals and Metals Division)  
 Electricity Association  
 Ministry of Defence  
 Society of Motor Manufacturers and Traders Limited

The following bodies were also represented in the drafting of the standard, through a subcommittee.

British Coal Corporation  
 Rotating Electrical Machines Association (BEAMA Ltd.)

## National annex NB (informative)

### Cross-references

Publication referred to	Corresponding British Standard
EN 10020:1988	BS EN 10020:1991 <i>Definition and classification of grades of steel</i>
EN 10052:1993	BS EN 10052:1993 <i>Vocabulary of heat treatment terms for ferrous products</i>
EN 10079:1992	BS EN 10079:1993 <i>Definition of steel products</i>
EN 10204:1991	BS EN 10204:1991 <i>Metallic products. Types of inspection documents</i> BS 5750 <i>Quality systems</i>
EN 29001:1987	Part 1:1987 <i>Specification for design/development, production, installation and servicing</i>
EN 29002:1987	Part 2:1987 <i>Specification for production and installation</i>
EN 29003:1987	Part 3:1987 <i>Specification for final inspection and test</i>
ISO 31-0:1981	BS 5775 <i>Specification for quantities, units and symbols</i> Part 0:1982 <i>General principles</i>

---

# BSI — British Standards Institution

BSI is the independent national body responsible for preparing British Standards. It presents the UK view on standards in Europe and at the international level. It is incorporated by Royal Charter.

## Revisions

British Standards are updated by amendment or revision. Users of British Standards should make sure that they possess the latest amendments or editions.

It is the constant aim of BSI to improve the quality of our products and services. We would be grateful if anyone finding an inaccuracy or ambiguity while using this British Standard would inform the Secretary of the technical committee responsible, the identity of which can be found on the inside front cover. Tel: 020 8996 9000. Fax: 020 8996 7400.

BSI offers members an individual updating service called PLUS which ensures that subscribers automatically receive the latest editions of standards.

## Buying standards

Orders for all BSI, international and foreign standards publications should be addressed to Customer Services. Tel: 020 8996 9001. Fax: 020 8996 7001.

In response to orders for international standards, it is BSI policy to supply the BSI implementation of those that have been published as British Standards, unless otherwise requested.

## Information on standards

BSI provides a wide range of information on national, European and international standards through its Library and its Technical Help to Exporters Service. Various BSI electronic information services are also available which give details on all its products and services. Contact the Information Centre. Tel: 020 8996 7111. Fax: 020 8996 7048.

Subscribing members of BSI are kept up to date with standards developments and receive substantial discounts on the purchase price of standards. For details of these and other benefits contact Membership Administration. Tel: 020 8996 7002. Fax: 020 8996 7001.

## Copyright

Copyright subsists in all BSI publications. BSI also holds the copyright, in the UK, of the publications of the international standardization bodies. Except as permitted under the Copyright, Designs and Patents Act 1988 no extract may be reproduced, stored in a retrieval system or transmitted in any form or by any means – electronic, photocopying, recording or otherwise – without prior written permission from BSI.

This does not preclude the free use, in the course of implementing the standard, of necessary details such as symbols, and size, type or grade designations. If these details are to be used for any other purpose than implementation then the prior written permission of BSI must be obtained.

If permission is granted, the terms may include royalty payments or a licensing agreement. Details and advice can be obtained from the Copyright Manager. Tel: 020 8996 7070.