

Charpy impact test on metallic materials —

Part 1: Test method (V-and U-notches)

This European Standard EN 10 045-1 has the status of a
British Standard

UDC 669:620.178.746.22

Cooperating organizations

The European Committee for Standardization, under whose supervision this European Standard was prepared, comprises the national standards organizations of the following Western European countries.

Austria	Oesterreichisches Normungsinstitut
Belgium	Institut belge de normalisation
Denmark	Dansk Standardiseringsraad
Finland	Suomen Standardisoimisliitto, r.y.
France	Association française de normalisation
Germany	Deutsches Institut für Normung e.V.
Greece	Hellenic Organization for Standardization
Iceland	Technological Institute of Iceland
Ireland	National Standards Authority of Ireland
Italy	Ente Nazionale Italiano di Unificazione
Luxemburg	Inspection du Travail et des Mines
Netherlands	Nederlands Normalisatie-instituut
Norway	Norges Standardiseringsforbund
Portugal	Instituto Português da Qualidade
Spain	Asociación Española de Normalización y Certificación
Sweden	Standardiseringskommissionen i Sverige
Switzerland	Association suisse de normalisation
United Kingdom	British Standards Institution

This British Standard, having been prepared under the direction of the Iron and Steel and the Non-ferrous Metals Standards Policy Committees, was published under the authority of the Board of BSI and comes into effect on 31 October 1990

© BSI 12-1998

First published, as BS 131-2 and 131-3, August 1920
 Second edition, as BS 131-2 and 131-3, August 1933
 Third edition, BS 131-2, November 1959
 BS 131-3, June 1962
 Fourth edition, as BS 131-2 and 131-3, March 1972
 Fifth edition, as BS EN 10 045-1, October 1990

The following BSI references relate to the work on this standard:
 Committee reference ISM/NFM/4
 Draft for comment 87/37631 DC

Amendments issued since publication

Amd. No.	Date of issue	Comments

ISBN 0 580 18809 4

Contents

	Page
Cooperating organizations	Inside front cover
National foreword	ii
<hr/>	
Brief history	2
Foreword	2
Text of EN 10 045-1:1990	3
<hr/>	
National appendix A	Inside back cover
National appendix B	Inside back cover
<hr/>	

National foreword

This Part of BS EN 10 045 has been prepared under the direction of the Iron and Steel and the Non-ferrous Metals Standards Policy Committees and is the English language version of EN 10 045-1 “Metallic materials — Charpy impact test — Part 1: Test method”, ratified by CEN/BT on 27 November 1989. It combines requirements for both V- and U- notches and supersedes BS 131-2:1972 and BS 131-3:1972 which are withdrawn.

A further Part of EN 10 045, in course of preparation, is listed in the foreword to EN 10 045-1 and annex A.

Cross-references. Where there are British Standards corresponding to European Standards and international standards quoted in this standard the relationship is given in national appendix B.

A British Standard does not purport to include all the necessary provisions of a contract. Users of British Standards are responsible for their correct application.

Compliance with a British Standard does not of itself confer immunity from legal obligations.

Summary of pages

This document comprises a front cover, an inside front cover, pages i and ii, the EN title page, pages 2 to 8, an inside back cover and a back cover.

This standard has been updated (see copyright date) and may have had amendments incorporated. This will be indicated in the amendment table on the inside front cover.

UDC 669:620.178.746.22

Key words: Metal products, mechanical tests, Charpy impact tests, test specimens, testing conditions.

English version

Metallic materials — Charpy impact test — Part 1: Test method

Matériaux métalliques — Essai de flexion par
choc sur éprouvette Charpy —
Partie 1: Méthode d'essai

Metallische Werkstoffe —
Kerbschlagbiegeversuch nach Charpy —
Teil 1: Prüfverfahren

This European Standard was accepted by CEN on 27 November 1989. CEN members are bound to comply with the requirements of the CEN/CENELEC Common Rules which stipulate the conditions for giving this European Standard the status of a national standard without any alteration.

Up-to-date lists and bibliographical references concerning such national standards may be obtained on application to the CEN Central Secretariat or to any CEN member.

This European Standard exists in three official versions (English, French, German). A version in any other language made by translation under the responsibility of a CEN member into its own language and notified to CEN Central Secretariat has the same status as the official versions.

CEN members are the national standard organizations of Austria, Belgium, Denmark, Finland, France, Germany, Greece, Iceland, Ireland, Italy, Luxemburg, Netherlands, Norway, Portugal, Spain, Sweden, Switzerland and United Kingdom.

CEN

European Committee for Standardization
Comité Européen de Normalisation
Europäisches Komitee für Normung

Central Secretariat: Rue Bréderode 2, B-1000 Brussels

Brief history

The proposal for this European Standard was prepared by the Technical Committee ECISS/TC1A “Mechanical and physical tests”, the Secretariat of which has been allocated to the Association Française de Normalisation (AFNOR).

It represents the first part of the general standard: Metallic materials — Impact test.

This European Standard replaces the Euronorms:

EU 7-55, Charpy impact test for steel.

EU-45-63, Impact testing using V-notch, beam type test piece.

This European Standard was adopted by CEN on 27 November 1989.

According to the Common CEN/CENELEC Rules, being part of the Internal Regulations of CEN, the following countries are bound to implement this European Standard:

Austria, Belgium, Denmark, Finland, France, Germany, Greece, Iceland, Ireland, Italy, Luxemburg, Netherlands, Norway, Portugal, Spain, Sweden, Switzerland and United Kingdom.

Foreword

The standard EN 10 045 concerns metallic materials — Charpy impact test and comprises the following parts:

— *Part 1: Method of test;*

— *Part 2: Verification of pendulum impact testing machines.*

Part 1 of EN 10 045 is based on the following ISO Standards:

ISO 83-1976, Steel — Charpy impact test (U-notch).

ISO 148-1983, Steel — Charpy impact test (V-notch).

Contents

	Page
Brief history	2
Foreword	2
1 Object and field of application	3
2 References	3
3 Principle	3
4 Designations	3
5 Test pieces	3
6 Testing machine	3
7 Test requirements	5
8 Test report	5
Annex A List of national standards corresponding to the reference European Standard in preparation	8
Figure 1 — Charpy impact test	6
Figure 2 — Configuration of test piece supports and anvils	7
Table 1 — Designations	3
Table 2 — Tolerances on specified test piece dimensions	4
Table 3 — Characteristics of testing machine	5
Table 4 — National standards corresponding to proposed European Standard	8

1 Object and field of application

1.1 This Part of this European Standard describes the Charpy impact test (U and V-notch) for metallic materials.

For certain particular metallic materials and applications, the Charpy impact test may be the subject of specific standards and particular requirements.

2 References

ISO 286-1-1988, ISO system of limits and fits — Part 1: General, tolerances and deviations.

EN 10 045-2¹⁾, Metallic materials — Charpy impact test — Part 2: Verification of pendulum impact testing machines.

3 Principle

The test consists of breaking by one blow from a swinging pendulum, under conditions defined hereafter, a test piece notched in the middle and supported at each end. The energy absorbed is determined in joules. This absorbed energy is a measure of the impact strength of the material.

4 Designations

The designations applicable to this standard are as indicated in Table 1 and Figure 1 and Figure 2.

Table 1 — Designations

Reference (see Figure 1 and Figure 2)	Designation	Unit
1	Length of test piece	mm
2	Height of test piece	mm
3	Width of test piece	mm
4	Height below notch	mm
5	Angle of notch	Degree
6	Radius of curvature of base of notch	mm
7	Distance between anvils	mm
8	Radius of anvils	mm
9	Angle of taper of each anvil	Degree
10	Angle of taper of striker	Degree
11	Radius of curvature of striker	mm
12	Width of striker	mm
—	Energy absorbed by breakage KU or KV	Joule

5 Test pieces

5.1 Sampling, number of test pieces and their location shall be as specified in the relevant product standard.

5.2 The standard test piece shall be 55 mm long and of square section with 10 mm sides. In the centre of the length, there shall be a notch. Two types of notch are specified.

a) V-notch of 45°, 2 mm deep with a 0,25 mm radius of curvature at base of notch.

If standard test pieces cannot be obtained from the material, a reduced section test piece, with a width of 7,5 mm or 5 mm (see Table 2) shall be used, the notch being cut in one of the narrow faces.

b) U-notch or keyhole notch, 5 mm deep, with a 1 mm radius of curvature at base of notch.

The test pieces shall be machined all over, except in the case of precision cast foundry test pieces in which the two faces parallel to the plane of symmetry of the notch can be unmachined.

5.3 The plane of symmetry of the notch shall be perpendicular to the longitudinal axis of the test piece.

5.4 The tolerances on the specified dimensions of the test piece shall be as given in Table 2.

5.5 Test pieces of widths other than those shown in Table 2, for example, with the unmachined widths equal to the thickness of the product, may be used provided this is permitted in the relevant product standard. Comparison of results, however, is only of significance when made between test pieces of the same form and dimensions.

5.6 Machining shall be carried out in such a way that any alteration of the test piece, for example due to cold working or heating, is minimized. The notch shall be carefully prepared so that no grooves, parallel to the base of the notch, are visible to the naked eye.

The test piece may be marked on any face not in contact with the supports or anvils and at a point at least 5 mm from the notch to avoid the effects of cold working due to marking.

6 Testing machine

6.1 The testing machine shall be constructed and installed rigidly and shall be in accordance with European Standard 10 045-2.

The values of the principal characteristics of the testing machine are specified in Table 3.

¹⁾ In preparation. Until this European Standard is published reference can be made to the corresponding national or international standards, a list of which is given in annex A.

6.2 Standard test conditions shall correspond to a nominal machine energy of 300 ± 10 J and the use of a test piece of standard dimensions. The reported absorbed energy under these conditions shall be designated by the symbols:

- KU for a U-notch test piece
- KV for a V-notch test piece

for example:

- KV = 121 J denotes:
 - nominal energy 300 J
 - standard V-notch test piece
 - energy absorbed during fracture: 121 J

6.3 Testing machines with different striking energies are permitted, in which case the symbol KU or KV shall be supplemented by an index denoting the energy of the testing machine:

for example:

- KV 150: available energy 150 J
- KU 100: available energy 100 J
- KU 100 = 65 J denotes:
 - nominal energy 100 J
 - standard U-notch test piece
 - energy absorbed during fracture: 65 J

Table 2 — Tolerances on specified test piece dimensions

Designation	U-notch test piece			V-notch test piece		
	Nominal dimension	Machining tolerance		Nominal dimension	Machining tolerance	
			ISO symbol ^a			ISO symbol ^a
Length	55 mm	$\pm 0,60$ mm	j_s 15	55 mm	$\pm 0,60$ mm	j_s 15
Height	10 mm	$\pm 0,11$ mm	j_s 13	10 mm	$\pm 0,60$ mm	j_s 12
Width:						
— standard test piece	10 mm	$\pm 0,11$ mm	j_s 13	10 mm	$\pm 0,11$ mm	j_s 13
— reduced section test piece	—	—	—	7,5 mm	$\pm 0,11$ mm	j_s 13
— reduced section test piece	—	—	—	5 mm	$\pm 0,06$ mm	j_s 12
Angle of notch	—	—	—	45°	$\pm 2^\circ$	—
Height below notch	5 mm	$\pm 0,09$ mm	j_s 13	8 mm	$\pm 0,06$ mm	j_s 12
Radius of curvature of base of notch	1 mm	$\pm 0,07$ mm	j_s 12	0,25 mm	$\pm 0,025$ mm	—
Distance of plane of symmetry of notch from ends of test piece ^b	27,5 mm	$\pm 0,42$ mm	j_s 15	27,5 mm	$\pm 0,42$ mm	j_s 15
Angle between plane of symmetry of notch and longitudinal axis of test piece	90°	$\pm 2^\circ$	—	90°	$\pm 2^\circ$	—
Angle between adjacent longitudinal faces of test piece	90°	$\pm 2^\circ$	—	90°	$\pm 2^\circ$	—

^a In accordance with ISO 286-1.

^b For machines with automatic positioning of the test piece, it is recommended that the tolerance be taken as $\pm 0,165$ mm instead of $\pm 0,42$ mm.

Table 3 — Characteristics of testing machine

Reference (Figure 1)	Designation	Value
7	Distance between anvils	$40_0^{+0,2}$ mm
8	Radius of anvils	$1_0^{+0,5}$ mm
9	Angle of taper of each anvil	$11^\circ \pm 1^\circ$
10	Angle of taper of striker	$30^\circ \pm 1^\circ$
11	Radius at tip of striker	$2_0^{+0,5}$ mm
12	Maximum width of striker	18 mm
—	Speed of striker at instant of impact	5 m/s to 5,5 m/s ^a
—	Angle between the support and the anvil	$90^\circ \pm 0,1^\circ$

^aFor machines manufactured prior to 1983, a speed of 4,5 m/s to 7 m/s is permissible by agreement.

6.4 For tests on a subsidiary V-notch test piece, the KV symbol shall be supplemented by indices denoting the first available energy of the testing machine and second the width of the test piece, e.g.

- KV 300/7,5: available energy 300 J, width of test piece 7,5 mm
- KV 150/5: available energy 150 J, width of test piece 5 mm
- KV 150/7,5 = 83 J denotes:
 - nominal energy 150 J
 - reduced section test piece of width 7,5 mm
 - energy absorbed during fracture: 83 J.

7 Test requirements

7.1 The test piece shall lie squarely against the anvils in such a way that the plane of symmetry of the notch shall be no more than 0,5 mm from the plane of symmetry of the anvils. The test piece shall lie on the supports in such a way that the tip of the striker hits the side opposite the notch of the test piece (see Figure 2).

7.2 If the test temperature is not specified in the relevant product standard, it shall be equal to $23^\circ\text{C} \pm 5^\circ\text{C}$.

If the temperature is specified in the relevant product standard without a tolerance, it shall be adhered to to within $\pm 2^\circ\text{C}$.

For tests at temperatures other than ambient, the test piece shall be immersed in the cooling or heating medium for sufficient time to ensure that the required temperature is reached throughout the test piece (for example, at least 10 min in a liquid medium or at least 30 min in a gaseous medium). The test piece shall be broken within 5 seconds of the time of removal from the medium.

The transfer device shall be designed and used in such a way that the temperature of the test piece is maintained within the temperature range permitted.

7.3 If, during the test, the test piece is deformed but not broken, the energy absorbed cannot be determined. The test report shall state that the test piece was not broken by x J.

NOTE It is emphasized that only results on test pieces of identical dimensions should be compared. There is no general method for converting the results obtained by one test method into the values which would be obtained by another test method.

8 Test report

The test report shall include the following information:

- a) reference to this standard, i.e. EN 10 045-1;
- b) the type and dimensions of the test piece;
- c) identification of the test piece (grade, cast no.....);
- d) direction and location of sampling where known;
- e) nominal energy of the striker;
- f) test temperature, in degrees Celsius;
- g) absorbed energy, KV or KU, in joules.

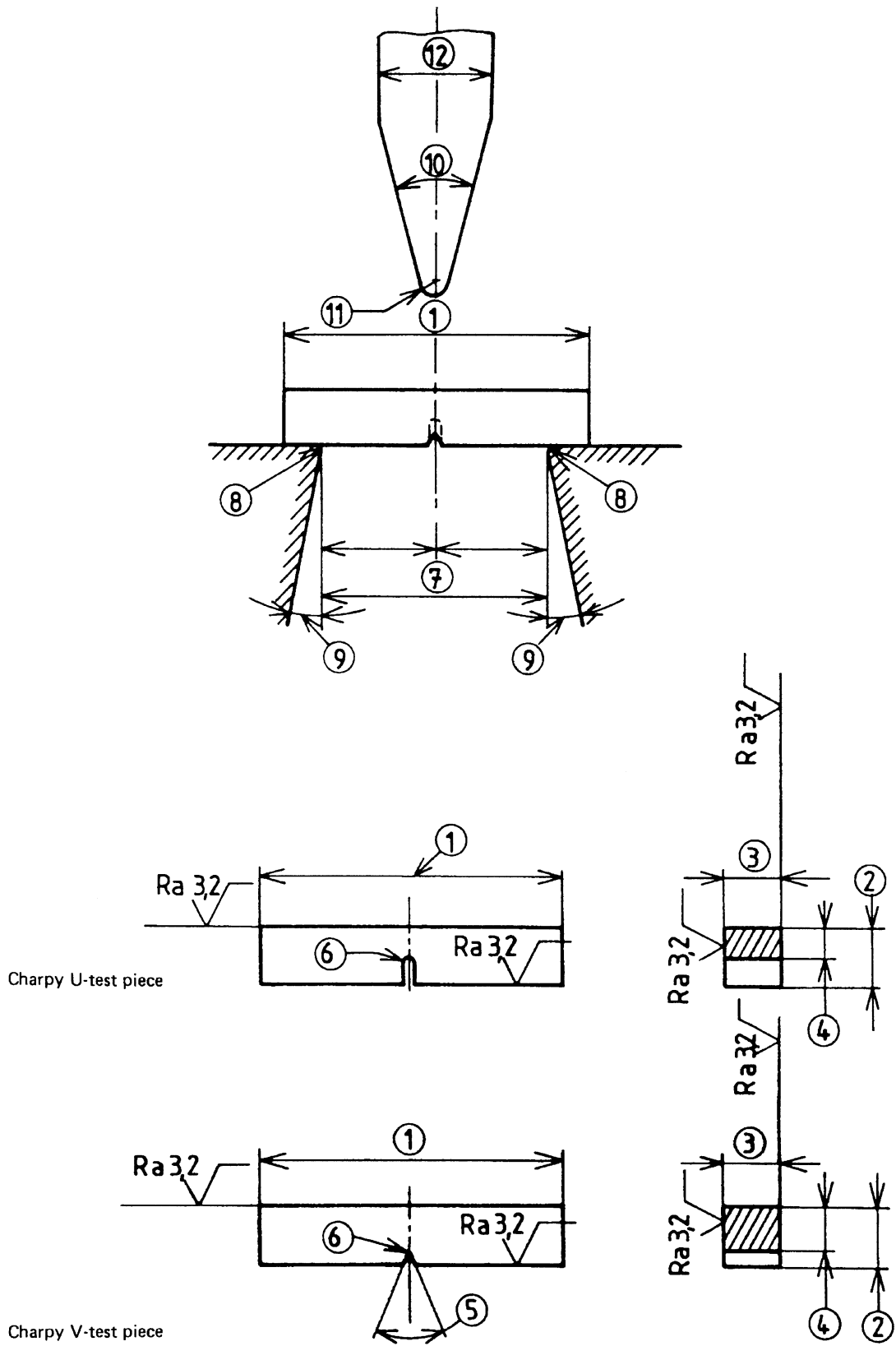

Charpy U-test piece

Charpy V-test piece

NOTE. See table 1 for explanation of reference numbers.

Figure 1 — Charpy impact test

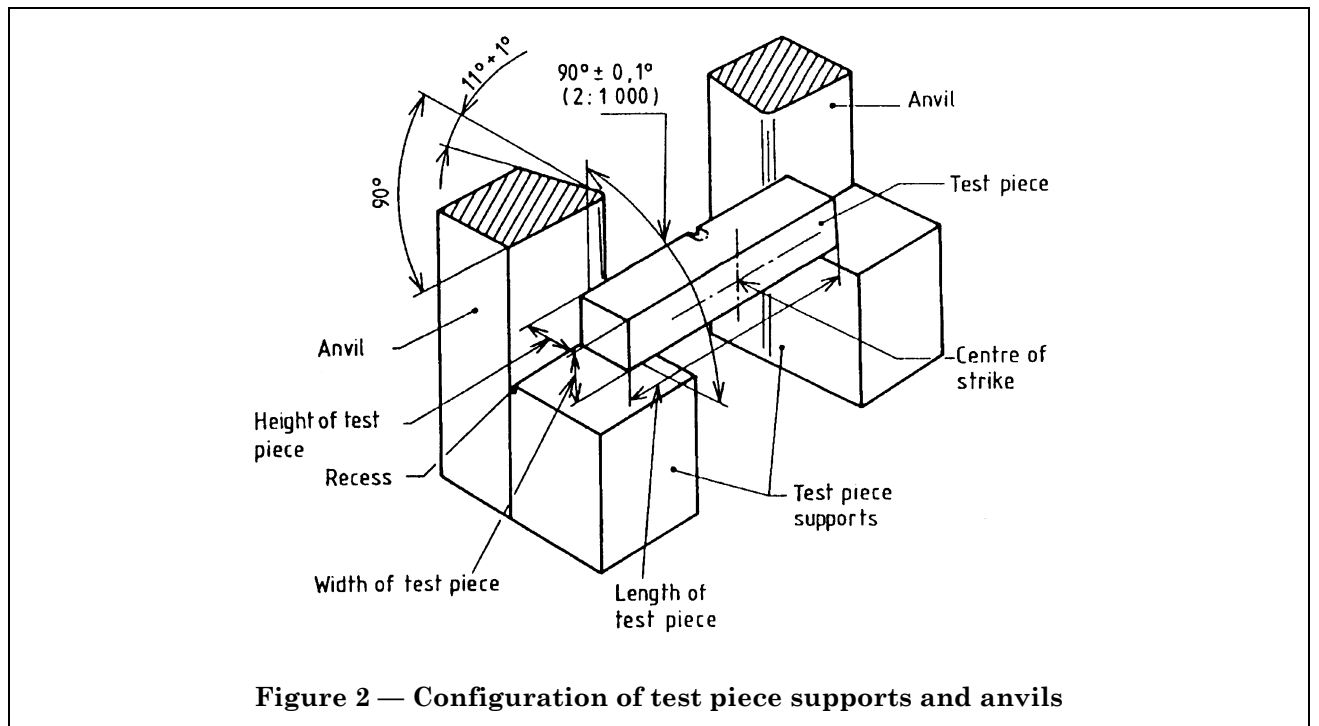

Figure 2 — Configuration of test piece supports and anvils

Annex A List of national standards corresponding to the reference European Standard in preparation

Until European Standard 10 045-2 has been prepared it is possible to refer to the corresponding national standards, a list of which is given in Table 4.

Table 4 — National standards corresponding to proposed European Standard

prEN	Corresponding national standard in						
	Germany	France	UK	Italy	Belgium	Sweden	ISO
10045-2	DIN 51 306 1983	NFA03-508-1985	BS 131-4:1972				442-1965

National appendix A

The United Kingdom participation in the preparation of this European Standard was entrusted by the Iron and Steel and the Non-ferrous Metals Standards Policy Committees (ISM/-and NFM/-) to Technical Committee ISM/NFM/4 upon which the following bodies were represented:

Aluminium Federation
 British Gas plc
 British Non-Ferrous Metals Federation
 British Railways Board
 British Steel Industry
 Copper Development Association
 Department of Trade and Industry (National Engineering Laboratory)
 Department of Trade and Industry (National Physical Laboratory)
 Department of Trade and Industry (National Measurement Accreditation Service)
 ERA Technology Ltd.
 GAMBICA (BEAMA Ltd.)
 Ministry of Defence
 Society of British Aerospace Companies Limited
 Welding Institute

The following bodies were also represented in the drafting of the standard, through subcommittees and panels:

BCIRA
 BEAMA Ltd.
 Electricity Supply Industry in England and Wales
 Lloyd's Register of Shipping
 Steel Casting Research and Trade Association
 United Kingdom Atomic Energy Authority

National appendix B

The British Standard corresponding to the ISO publication referred to in EN 10 045-1 is as follows:

International standard	British Standard
ISO 286-1-1988	BS 4500 ISO limits and fits Section 1.1:1990 Specification for bases of tolerances, deviations and fits (Identical)

A related British Standard to EN 10 045-2²⁾ referred to in EN 10 045-1 is BS 131 "Methods for notched bar tests: Part 4:1972 Calibration of pendulum impact testing machines for metals".

²⁾ In preparation.

BSI — British Standards Institution

BSI is the independent national body responsible for preparing British Standards. It presents the UK view on standards in Europe and at the international level. It is incorporated by Royal Charter.

Revisions

British Standards are updated by amendment or revision. Users of British Standards should make sure that they possess the latest amendments or editions.

It is the constant aim of BSI to improve the quality of our products and services. We would be grateful if anyone finding an inaccuracy or ambiguity while using this British Standard would inform the Secretary of the technical committee responsible, the identity of which can be found on the inside front cover. Tel: 020 8996 9000. Fax: 020 8996 7400.

BSI offers members an individual updating service called PLUS which ensures that subscribers automatically receive the latest editions of standards.

Buying standards

Orders for all BSI, international and foreign standards publications should be addressed to Customer Services. Tel: 020 8996 9001. Fax: 020 8996 7001.

In response to orders for international standards, it is BSI policy to supply the BSI implementation of those that have been published as British Standards, unless otherwise requested.

Information on standards

BSI provides a wide range of information on national, European and international standards through its Library and its Technical Help to Exporters Service. Various BSI electronic information services are also available which give details on all its products and services. Contact the Information Centre. Tel: 020 8996 7111. Fax: 020 8996 7048.

Subscribing members of BSI are kept up to date with standards developments and receive substantial discounts on the purchase price of standards. For details of these and other benefits contact Membership Administration. Tel: 020 8996 7002. Fax: 020 8996 7001.

Copyright

Copyright subsists in all BSI publications. BSI also holds the copyright, in the UK, of the publications of the international standardization bodies. Except as permitted under the Copyright, Designs and Patents Act 1988 no extract may be reproduced, stored in a retrieval system or transmitted in any form or by any means – electronic, photocopying, recording or otherwise – without prior written permission from BSI.

This does not preclude the free use, in the course of implementing the standard, of necessary details such as symbols, and size, type or grade designations. If these details are to be used for any other purpose than implementation then the prior written permission of BSI must be obtained.

If permission is granted, the terms may include royalty payments or a licensing agreement. Details and advice can be obtained from the Copyright Manager. Tel: 020 8996 7070.